

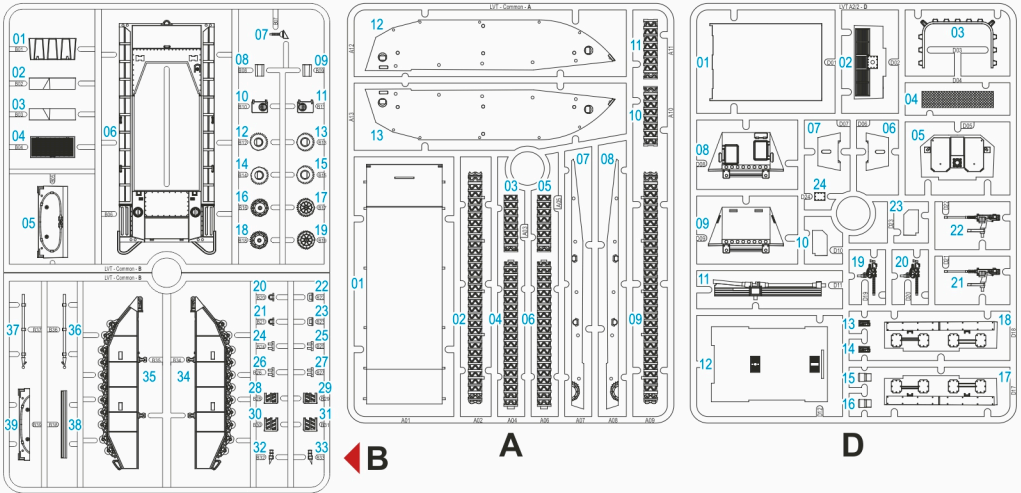

Product Code: 280067  
180621-2



- When you use glue or paint, do not use near a naked flame, and use in a well-ventilated area.
- When assembling this kit, tools including knives are used. Extra care should be taken to avoid personal injury.
- Keep out of reach of small children.

Read carefully and fully understand the instructions before commencing assembly. Model supplied unpainted. Bases, scenery, glue and paint not included. Legend used:



 Please use **ABS Plastic Cement** for our plastic kits.

### WARNING

- THIS IS NOT A TOY
- INTENDED FOR COLLECTORS OF AGE 14 AND ABOVE
- CONTAINS SMALL PARTS AND POINTED COMPONENTS
- NOT SUITABLE FOR CHILDREN UNDER 6 YEARS OLD
- MODEL MAY VARY FROM IMAGE ON BOX
- READY TO ASSEMBLE PRECISION MODEL KIT

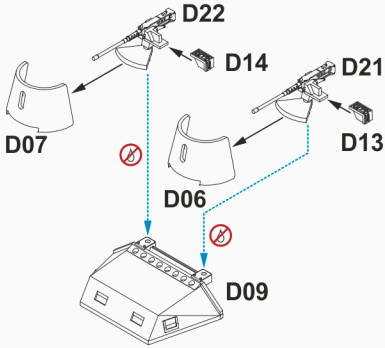
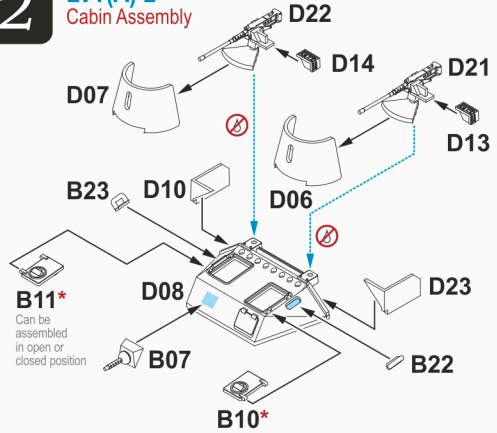
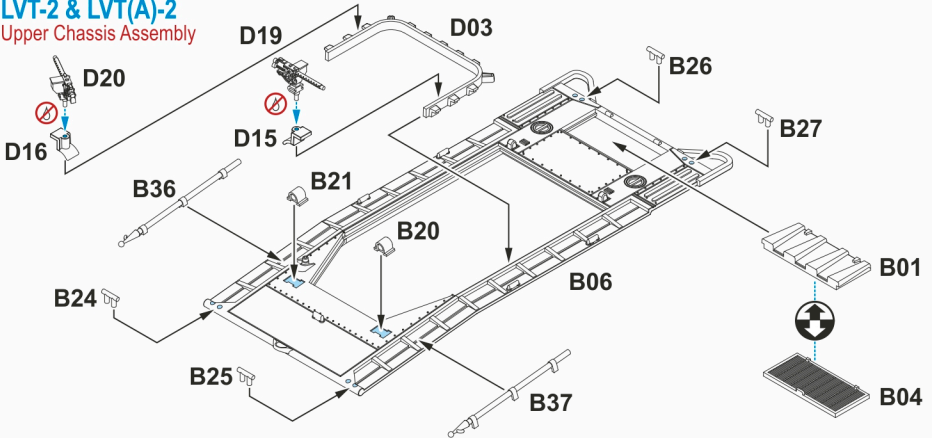
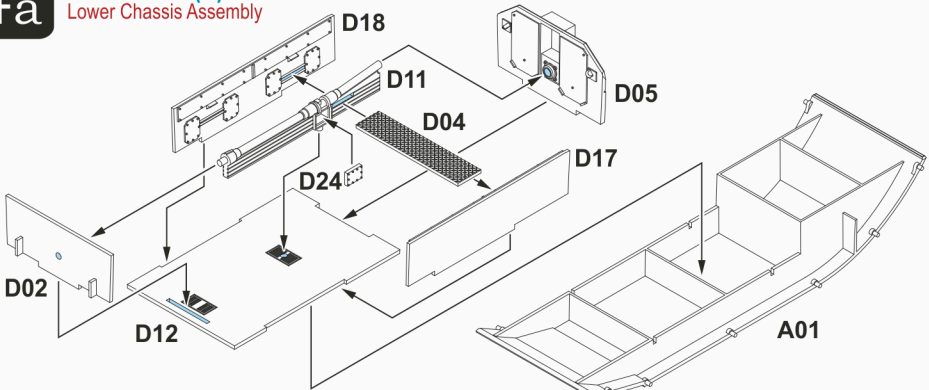
**1****LVT-2**  
Cabin Assembly**2****LVT(A)-2**  
Cabin Assembly**3****LVT-2 & LVT(A)-2**  
Upper Chassis Assembly**4a****LVT-2 & LVT(A)-2**  
Lower Chassis Assembly

# 4b

**DO THIS FIRST!**

Remove extra bits from **A12** with a cutter before assembly

A12

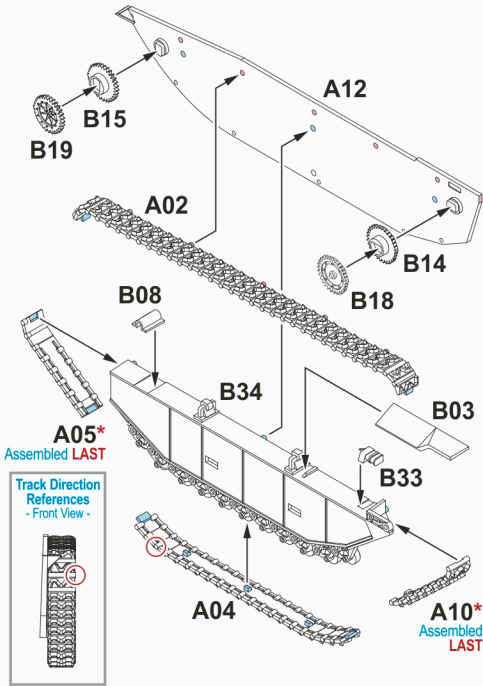

# 4c

**DO THIS FIRST!**

Remove extra bits from **A13** with a cutter before assembly

A13

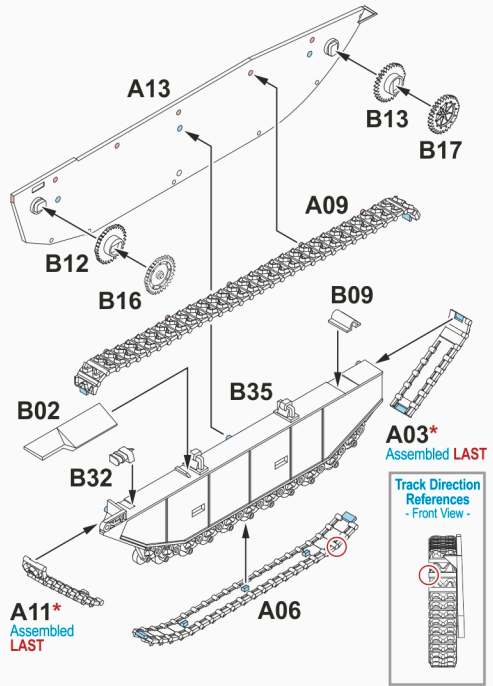

# 4d

**LVT-2 & LVT(A)-2**  
Lower Hull Assembly

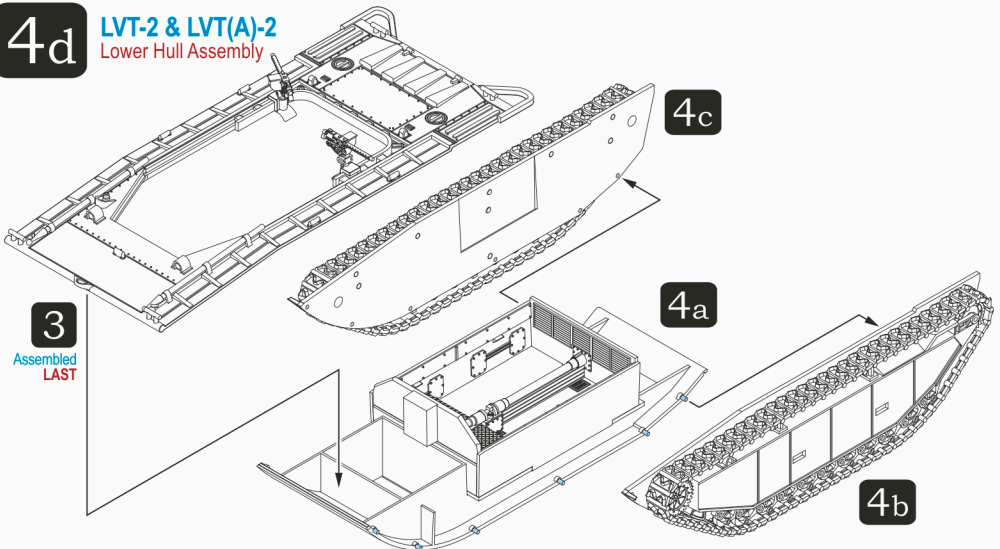

# 4e

## LVT-2 & LVT(A)-2 Final Assembly

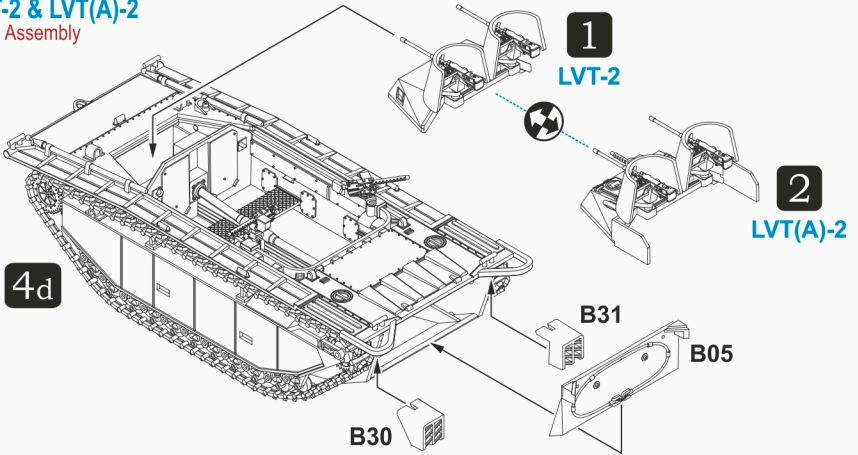

# 5a

## LVT-2 & LVT(A)-2 Waterline Version Assembly

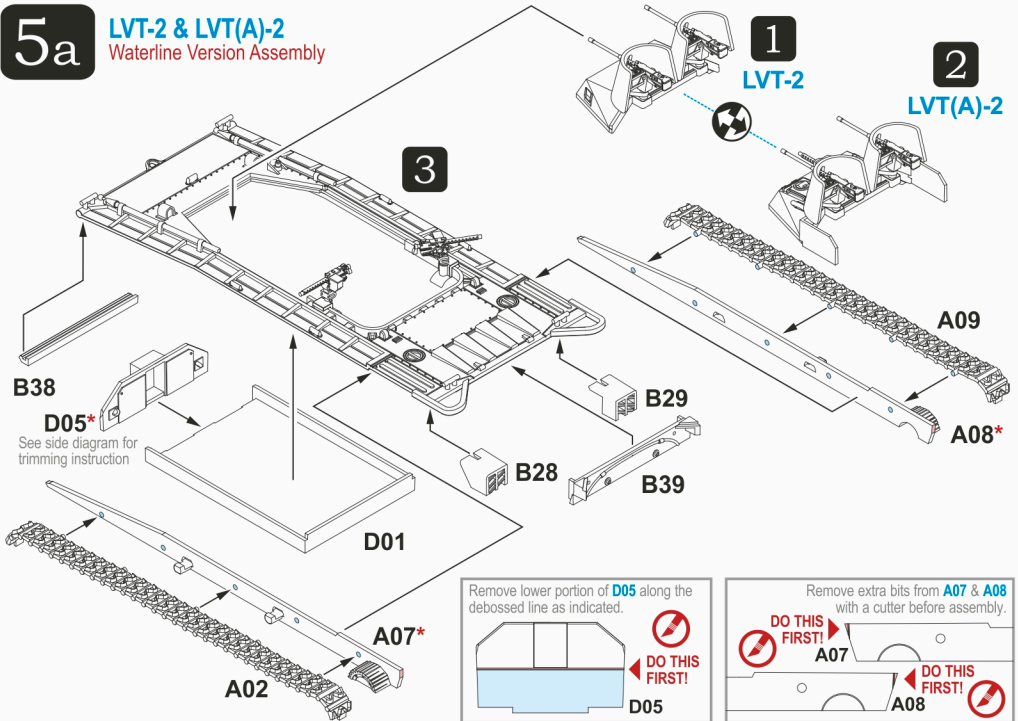

# 5b

## LVT-2 & LVT(A)-2 Waterline Final Assembly

