

Product Code: 230062
230302-2

JA (A)

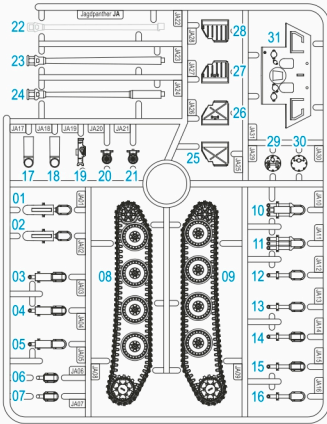

C

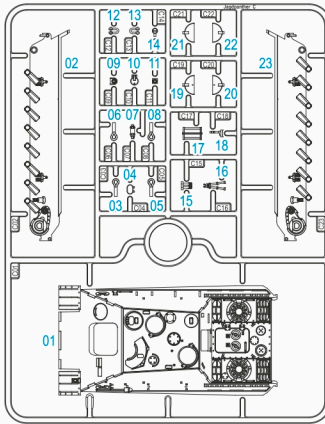

D

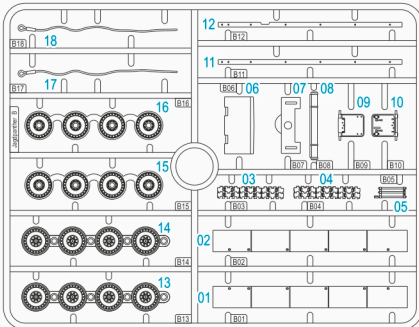
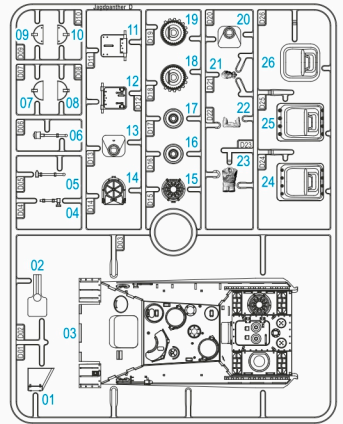

◀ B

CAUTION

Read carefully and fully understand the instructions before commencing assembly. Model supplied unpainted. Bases, scenery, glue and paint not included. Meaning of symbols used:

- When you use glue or paint, do not use near a naked flame, and use in a well-ventilated area.
- When assembling this kit, tools including knives are used. Extra care should be taken to avoid personal injury.

- Choices
- Open hole
- Please use **ABS Plastic Cement** for assembly.

- Optional
- Bend

- No glue
- Cut or trim with care

WARNING

- THIS IS NOT A TOY
- INTENDED FOR COLLECTORS OF AGE 14 AND ABOVE
- CONTAINS SMALL PARTS AND POINTED COMPONENTS
- NOT SUITABLE FOR CHILDREN UNDER 6 YEARS OLD
- MODEL MAY VARY FROM IMAGE ON BOX
- READY TO ASSEMBLE PRECISION MODEL KIT

© Rubicon Models Ltd 2019, 2023. Rubicon Models, the Rubicon Models Logo are trademarks of Rubicon Models Ltd. All rights reserved.



READ THIS FIRST BEFORE ASSEMBLY STARTS...

Please study the instruction thoroughly **before** actual assembly. This kit enables you to build either a **SdKfz 173 Jagdpanther G1** or **G2** tank destroyer. It is also good practice to *test fit* all parts and study all build options *before* gluing them together. This will save you time and frustrations!

Throughout the instruction, parts on **Sprue JA** is referred to as **"A"** for ease of identification.

Differences between the G1 and the G2...

The earlier (1944 model) **G1** with a small internally bolted main gun mantlet and a modified Panther A engine deck, and the later (1945 model) **G2** with a larger simplified, outside-bolted mantlet and a modified Panther G engine deck, though some late G1s also had the larger mantlet. Early Jagdpanther had two vision openings for the driver, whereas late versions had only one. The main gun originally had a monobloc gun barrel, but from May 1944 onward it was gradually replaced by a two-part barrel which was more economical as barrel wear was not even.

1

Lower Hull Assembly

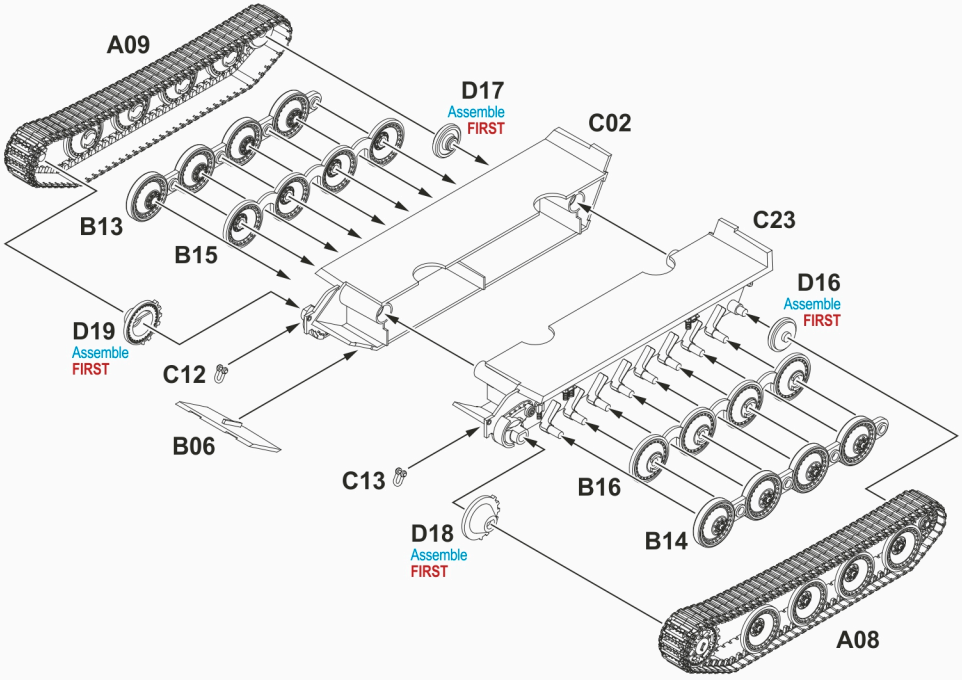

2

Periscope Assembly

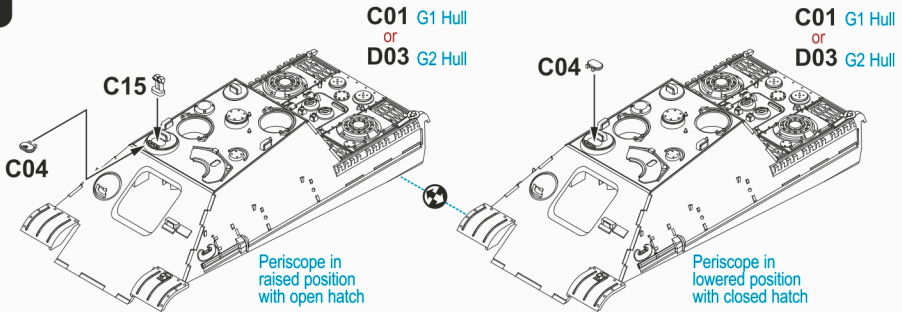

3a

Jagdpanther G1 Assembly

For G2 goto Step 4a

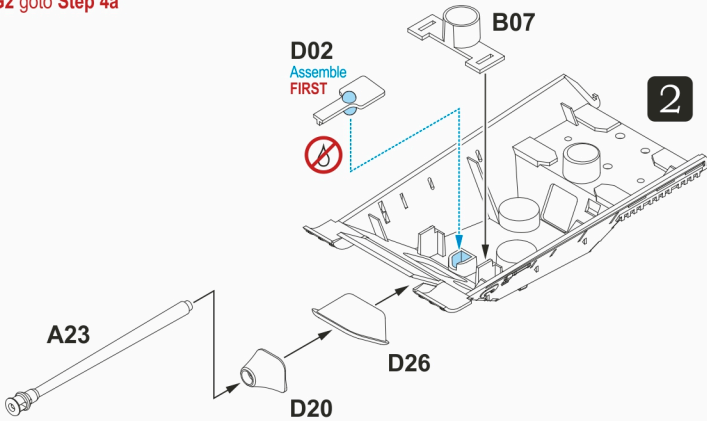

3b

Jagdpanther G1 Assembly

Right Side & Upper Hull

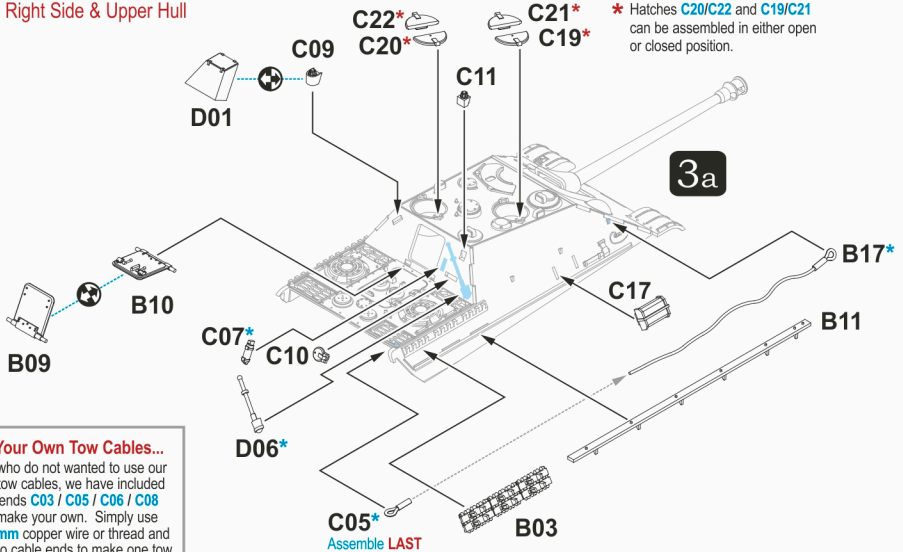

* Hatches C20/C22 and C19/C21 can be assembled in either open or closed position.



Making Your Own Tow Cables...
 For those who do not want to use our pre-made tow cables, we have included four cable ends C03 / C05 / C06 / C08 for you to make your own. Simply use either 0.8 mm copper wire or thread and connect two cable ends to make one tow cable.

* Optional

If you like this Jagdpanther G1/G2 heavy tank destroyer, you might also want to take a look at our other German vehicles, ranging from tanks, trucks, light vehicles, to motorcycles. Rubicon Models also have a wide range of plastic and pewter figures to go with our WW2 vehicle products. For more info, please visit our [Regional Webstores](#)...



RUBICON MODELS
 ASIA PACIFIC
www.rubiconmodelsasia.com



RUBICON MODELS
 UNITED KINGDOM
www.rubiconmodels.co.uk



RUBICON MODELS
 UNITED STATES
www.rubiconmodelsusa.com

Facebook icon: Please also visit our official Facebook page at <https://www.facebook.com/rubiconmodels>

Facebook icon: Follow our Facebook page to show your support!

3c

Jagdpanther G1 Assembly Left Side & Front Hull

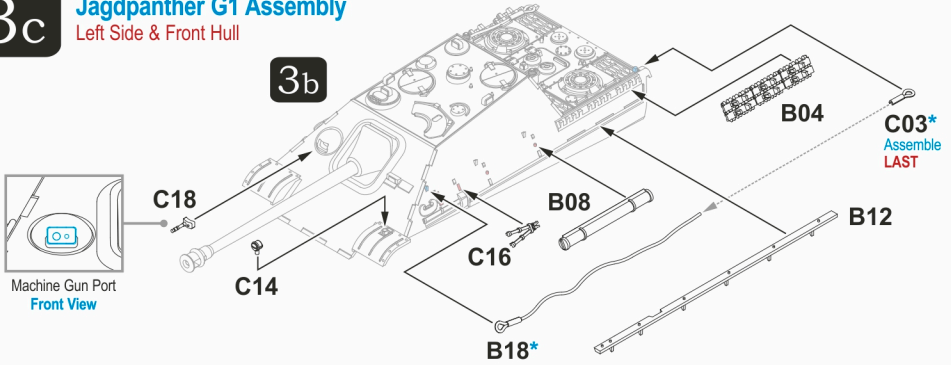

* Optional

3d

Jagdpanther G1 Assembly Rear Stowage Box & Exhaust Options

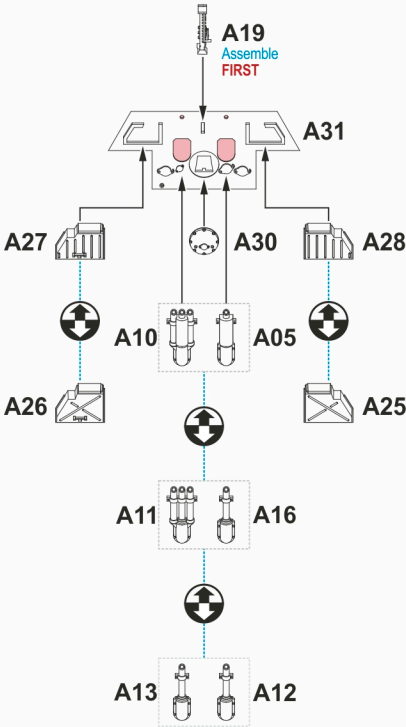

3e

Jagdpanther G1 Final Assembly

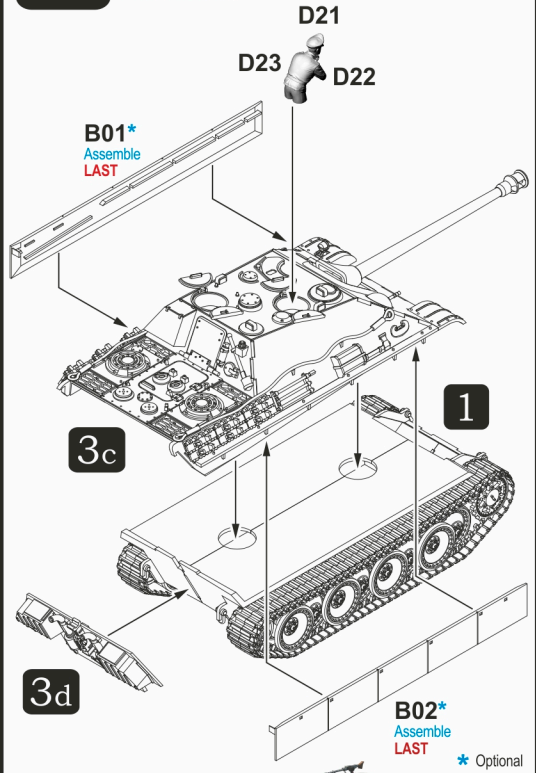

* Optional



Conversion Tips for Panther Ausf D/A & Ausf G

This Jagdpanther kit includes multiple sets of rear exhausts. If you own our Panther Ausf D/A (280014) or Panther Ausf G (280015) kits, you can use these unused exhaust sets to add variety to your models with only minor conversion work. We have also included an upgraded Panther gun barrel (A22) for your use.



4a

Jagdpanther G2 Assembly

Gun Barrel Cleaning Rods

Cleaning Rods: Both **B05** and **B08** are gun barrel cleaning rods, but of a different layout. **Only one set** is required.

Possible Placement: There are **three** possible locations for placing the cleaning rods on a Jagdpanther G2.

Using B05: Follow **Step 4c** for placement location.

Using B08: There are **two** possible locations for using the cleaning rod storage tube. **Drill two holes** using the diagrams on the right as references. Most common is on the side, but some tank crew had moved the tube to the rear engine deck. If that is the case, part **D04** and **D05** will need to be relocate elsewhere or simply not used. See **Step 4d** for references.

Gun Barrel Cleaning Rods



4b

Jagdpanther G2 Assembly

Gun and Hull Underside

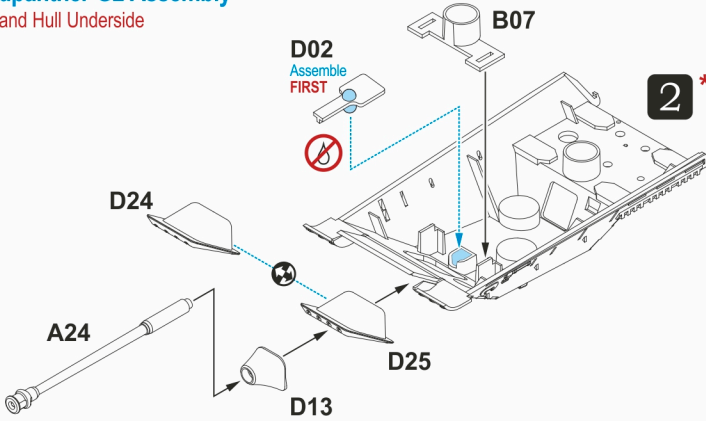

4c

Jagdpanther G2 Assembly

Right Side & Upper Hull

* Hatches **D08/D10** and **D07/D09** can be assembled either closed or open.

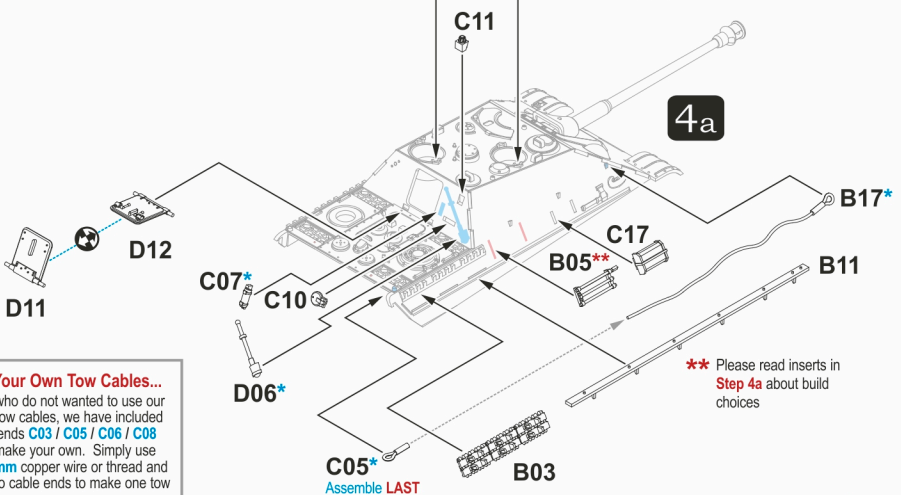

Making Your Own Tow Cables...

For those who do not want to use our pre-made tow cables, we have included four cable ends **C03 / C05 / C06 / C08** for you to make your own. Simply use either **0.8 mm** copper wire or thread and connect two cable ends to make one tow cable.

4d

Jagdpanther G2 Assembly Left Side & Front Hull

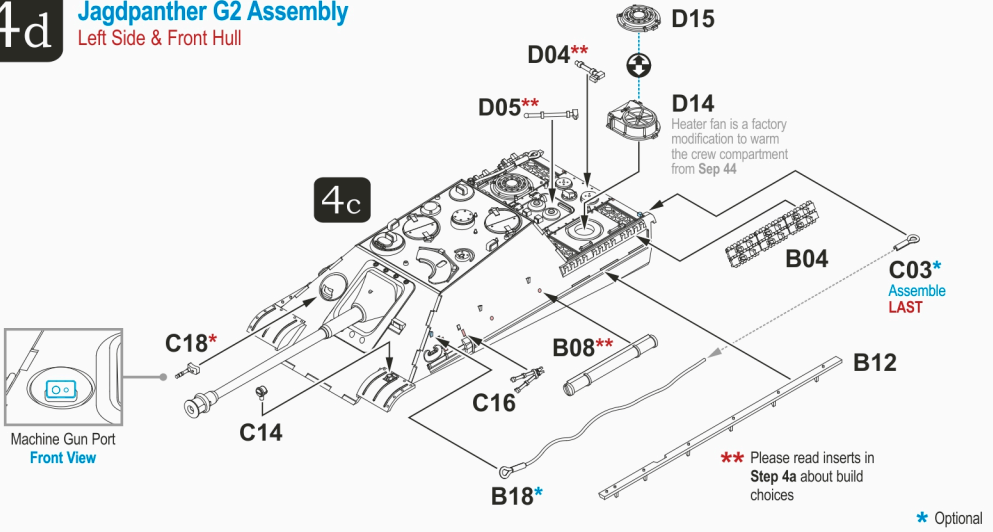

4e

Jagdpanther G2 Assembly Rear Stowage Box & Exhaust Options

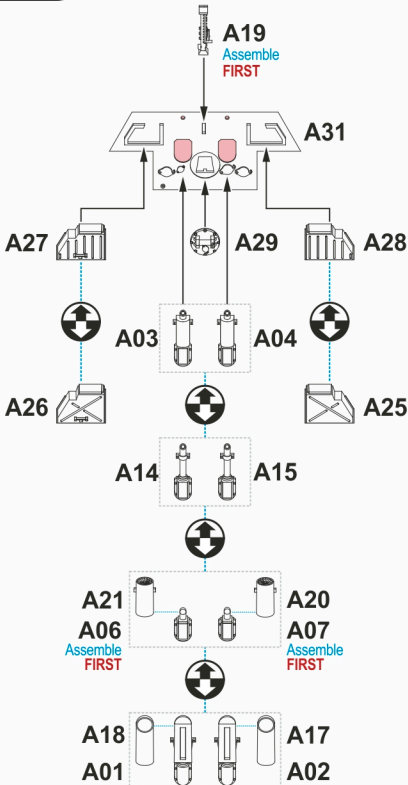

4f

Jagdpanther G2 Finalising the Assembly

