

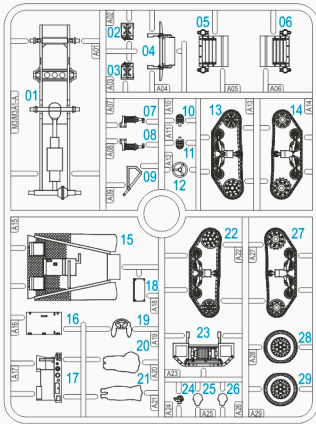

Product Code: 280027  
220503-1

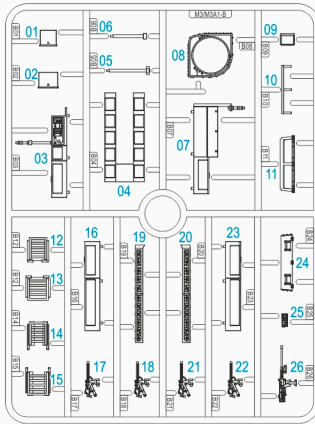

**A**



**B**



**C**



- When you use glue or paint, do not use near a naked flame, and use in a well-ventilated area.
- When assembling this kit, tools including knives are used. Extra care should be taken to avoid personal injury.
- Keep out of reach of small children.

Read carefully and fully understand the instructions before commencing assembly. Model supplied unpainted. Bases, scenery, glue and paint not included. Legend used:



Choices



Optional



No glue



Drill hole



Bend



Cut or trim with care

 Please use **ABS Plastic Cement** for our plastic kits.

### WARNING

- THIS IS NOT A TOY
- INTENDED FOR COLLECTORS OF AGE 14 AND ABOVE
- CONTAINS SMALL PARTS AND POINTED COMPONENTS
- NOT SUITABLE FOR CHILDREN UNDER 6 YEARS OLD
- MODEL MAY VARY FROM IMAGE ON BOX
- READY TO ASSEMBLE PRECISION MODEL KIT

**1****M3A1**

Punch 2 holes

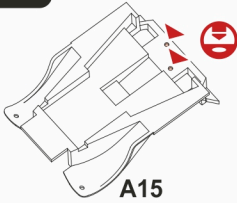
**M3**

Punch 4 holes

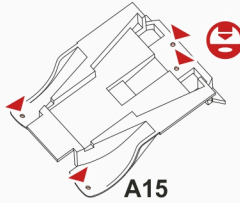
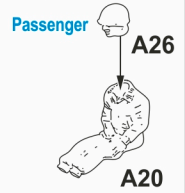
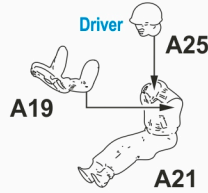
**2a****2b****3a****M3 / M3A1**

without Driver

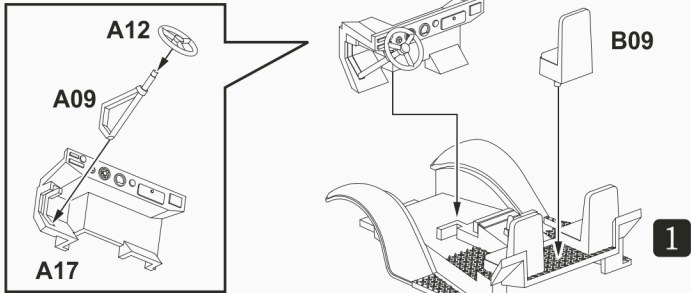
**3b****M3 / M3A1**

with Driver

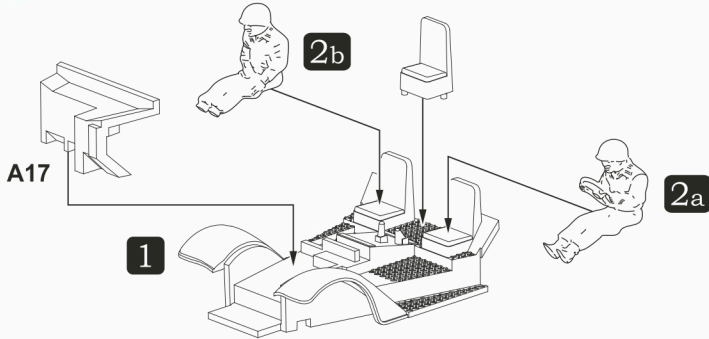
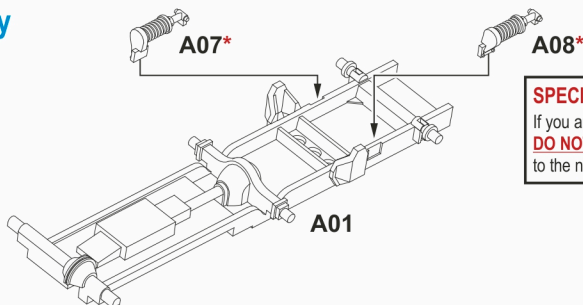
**4****M3A1 Only****SPECIAL ASSEMBLY NOTE**

If you are building the earlier M3, you **DO NOT** need A07 and A08. Proceed to the next step (Step 5).

# 5

## M3 / M3A1

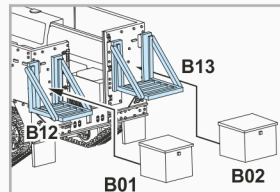
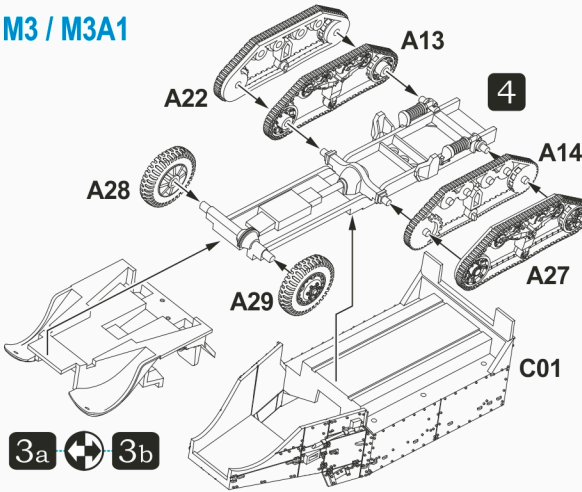

M3A1 with storage box

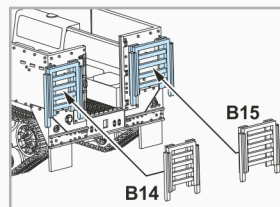

M3A1 with racks retracted

### WINDSHIELD TEMPLATE

for experienced modellers

Use the template provided if you decided to add a windshield to the M3/M3A1 Half Track.

To create the windshield, you will need a transparent film or simply the clear plastic from your miniature blister pack. Either trace the outline from the template or print it out using a printer. Apply the prepared windshield to the window frame from behind.

You can also download a digital copy of this template from our forum at [forum.rubiconmodels.com](http://forum.rubiconmodels.com) under "Painting & Assembly Guides". To download any files, you must register as a forum member.

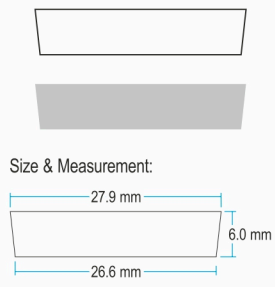

For our latest projects, updates, and product news, please visit our official Facebook pages as follow:

Please visit our Facebook page at: [www.facebook.com/rubiconmodels](http://www.facebook.com/rubiconmodels)

Our RM Community Group: [www.facebook.com/groups/rubiconmodelscommunity](http://www.facebook.com/groups/rubiconmodelscommunity)

Like our pages to show your support!

Our RM Community Video Channel: [www.youtube.com/rubiconmodels](http://www.youtube.com/rubiconmodels)

# 6a

## M3 Only

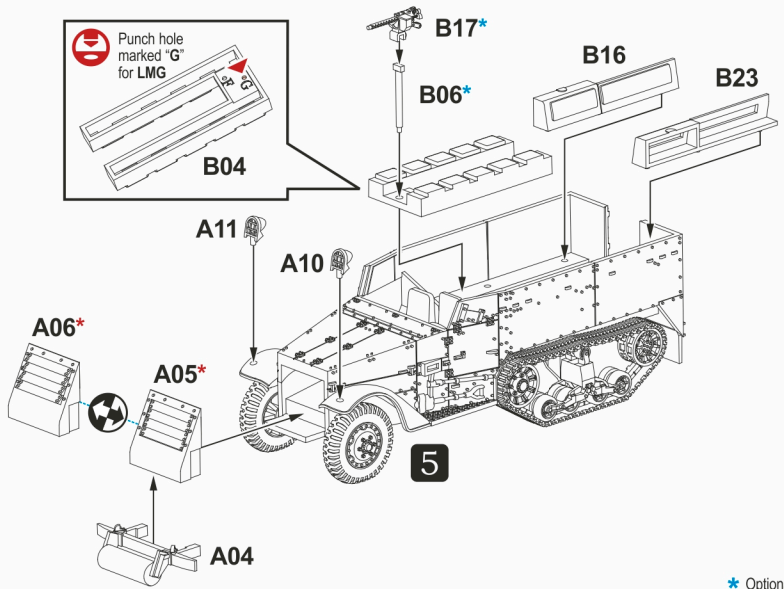
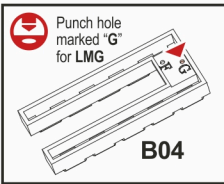

The lights on the M3 are on top of the fender. Remove lights on the armoured ventilation compartment with a sharp knife.

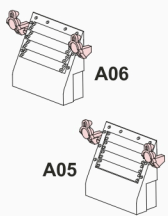

Choose between opened (A06) or closed (A05) armoured louvers.

\* Optional

# 6b M3A1 Only

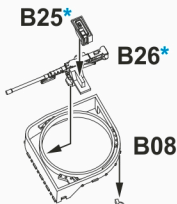

B05

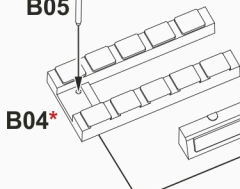

5

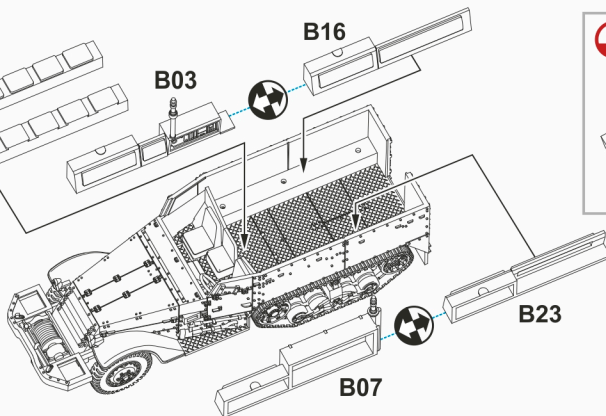

★ Optional



**HISTORICAL FACTS:** The Carrier, Personnel Half Track M3, also known as the M3 Half Track, was an American armoured personnel carrier widely used by the Allies during World War Two and into the Cold War. Derived from the M2 Half Track Car, the slightly longer M3 was extensively produced, with over **41,000** units were manufactured. The M3 and its variants were supplied to the US Army and Marines, as well as British Commonwealth and Soviet Red Army forces, serving on all major fronts throughout the war. The **M3A1** had the improved M49 machine gun mount over the right hand front seat. Between 1942 and 1943 all M3 Half-Tracks (standard and A1s) were continually upgraded. These improvements included a number of drive train, engine, and stowage improvements.

# 7 M3 / M3A1 unless marked

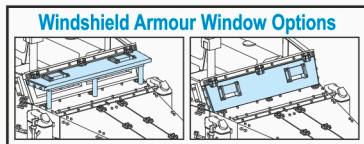
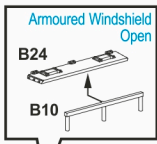
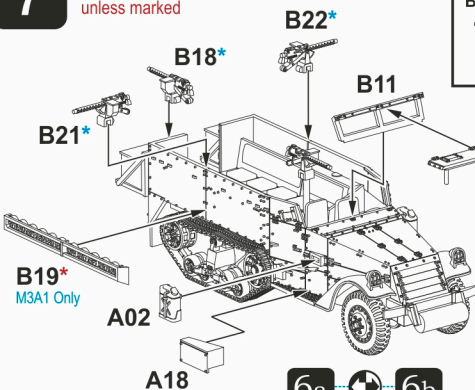

Rear door can be assembled in open or close position

6a 6b

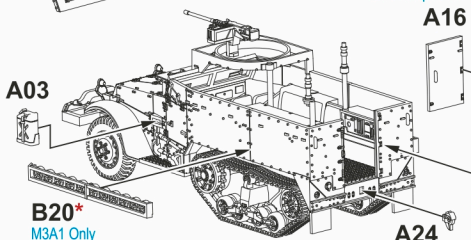

★ Optional