

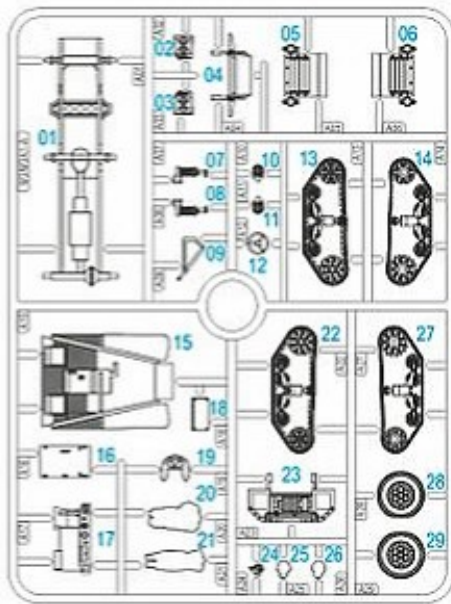

Product Code: 280027
 Revision: 200503-1

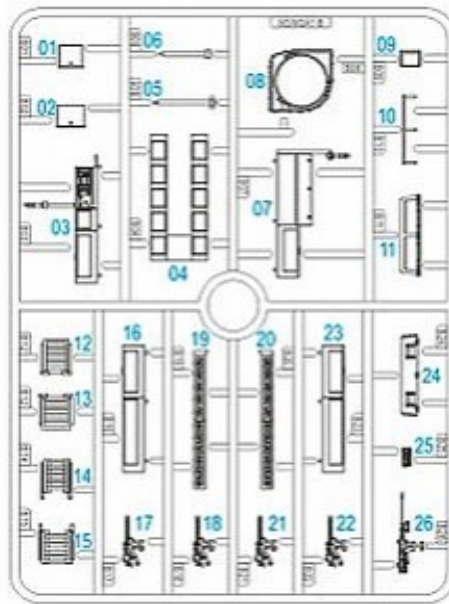

A



B



C



- When you use glue or paint, do not use near a naked flame, and use in a well-ventilated area.
- When assembling this kit, tools including knives are used. Extra care should be taken to avoid personal injury.
- Keep out of reach of small children.

Read carefully and fully understand the instructions before commencing assembly. Model supplied unpainted. Bases, scenery, glue and paint not included. Meaning of symbols used:



Choices



Optional



No glue



Drill hole



Bend



Cut or trim with care

Please use **ABS Plastic Cement** for our products.

WARNING:

Contains small parts which may be hazardous to children under 14 years of age.

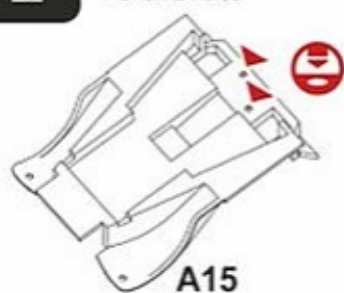

1**M3A1**
Punch 2 holes

A15

M3

Punch 4 holes

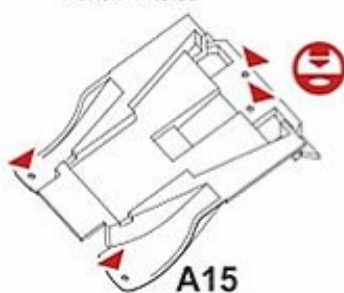

A15

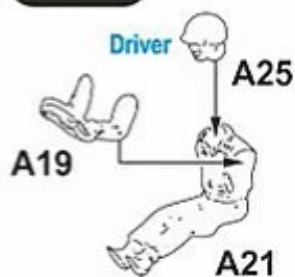
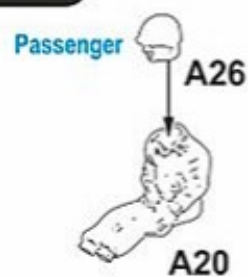
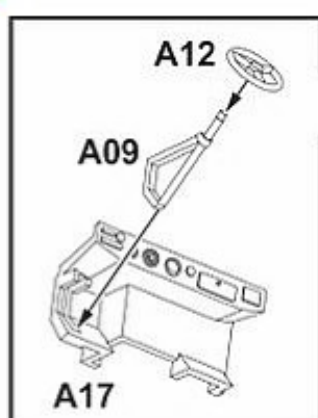
2a**2b****3a****M3 / M3A1**
without Driver

A17

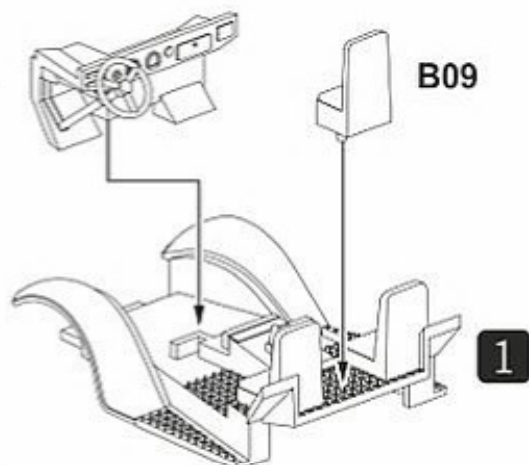

B09

1

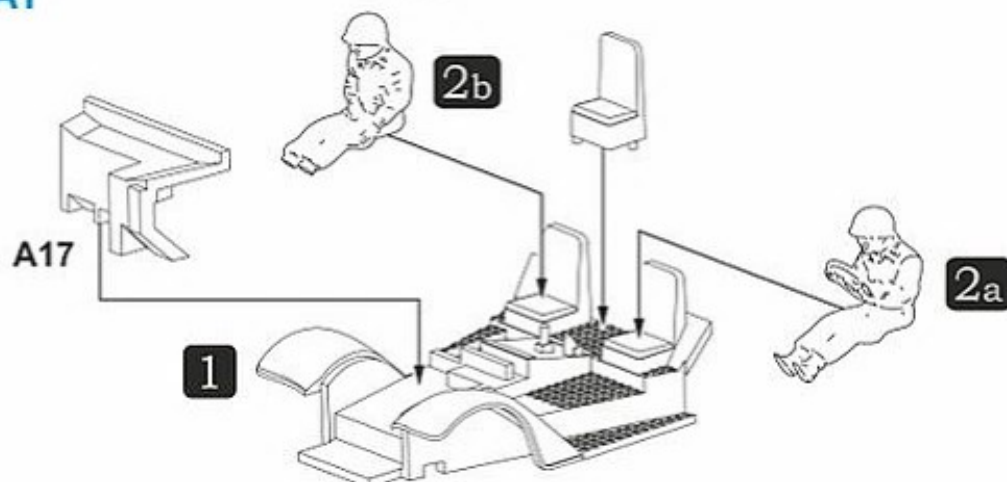
**3b****M3 / M3A1**
with Driver

A17

2b

2a

1

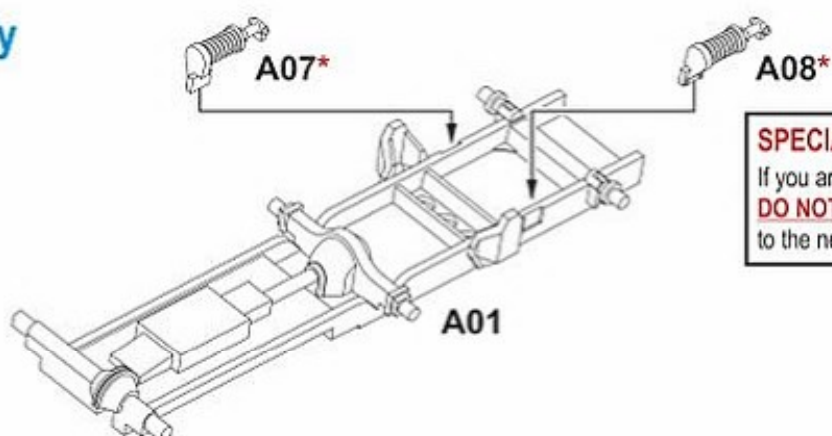
4**M3A1 Only**

A07*

A08*

A01

SPECIAL ASSEMBLY NOTE

If you are building the earlier M3, you **DO NOT** need A07 and A08. Proceed to the next step (Step 5).

5

M3 / M3A1

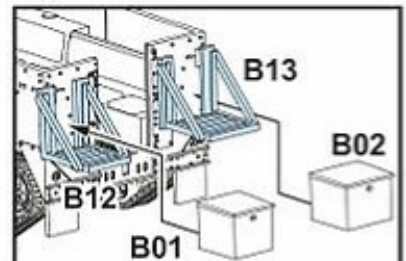
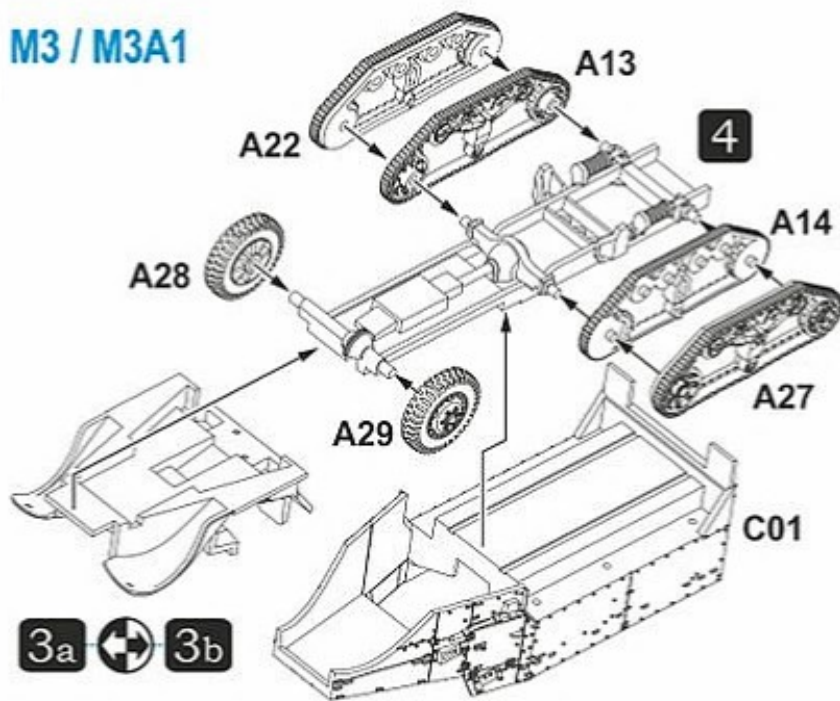

M3A1 with storage box

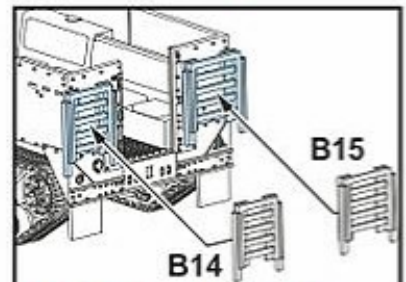

M3A1 with racks retracted

WINDSHIELD TEMPLATE

for experienced modellers

Use the template provided if you decided to add a windshield to the M3/M3A1 Half Track.

To create the windshield, you will need a transparent film or simply the clear plastic from your miniature blister pack. Either trace the outline from the template or print it out using a printer. Apply the prepared windshield to the window frame from behind.

You can also download a digital copy of this template from our forum at forum.rubiconmodels.com under "Painting & Assembly Guides". To download any files, you must register as a forum member.

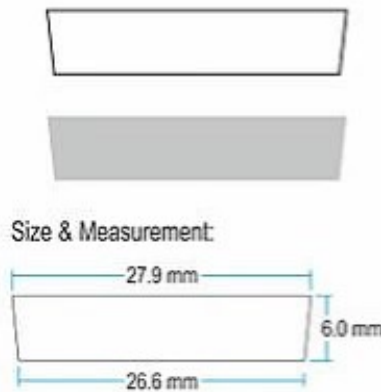

For upcoming new project & updates, please visit our official forum and Facebook pages, or visit our website at www.rubiconmodels.com.

Please visit our Facebook page at: www.facebook.com/rubiconmodels

and like our page to show your support!

Visit our official forum at: forum.rubiconmodels.com

Our RM Community Group: www.facebook.com/groups/rubiconmodelscommunity

Our RM Community Video Channel: www.youtube.com/rubiconmodels

6a

M3 Only



Punch hole marked "G" for LMG

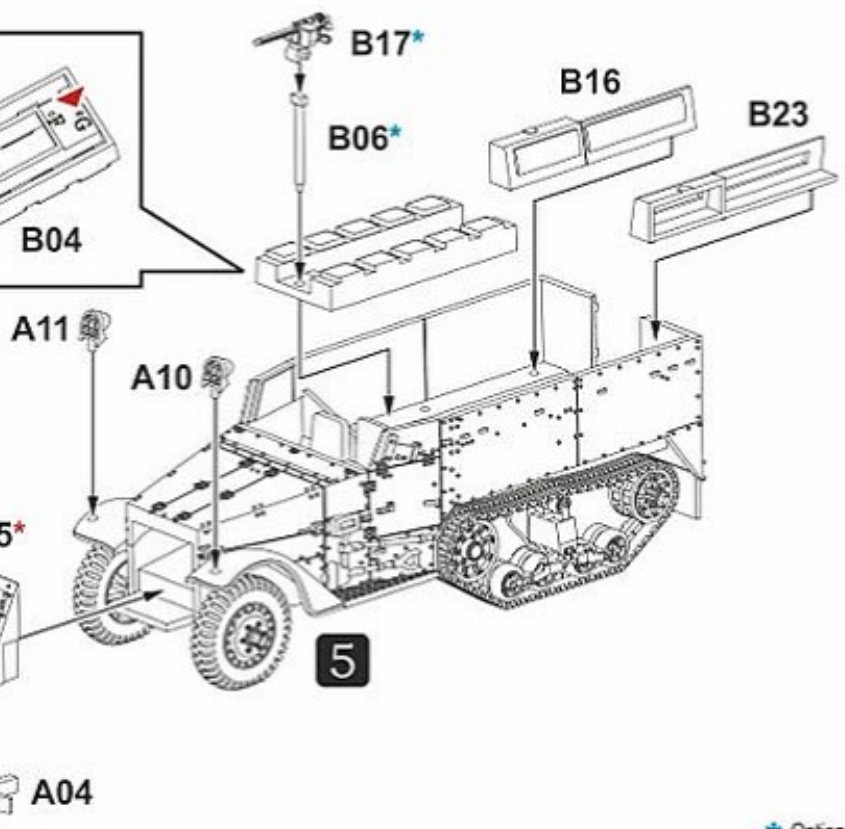

The lights on the M3 are on top of the fender. Remove lights on the armoured ventilation compartment with a sharp knife.



Choose between opened (A06) or closed (A05) armoured louvers.

* Optional

6b M3A1 Only

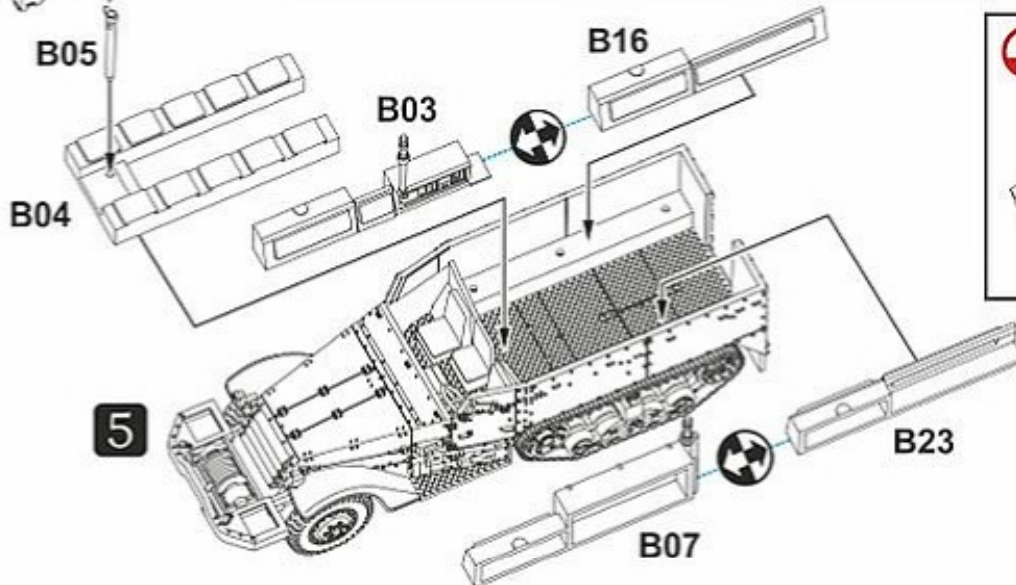
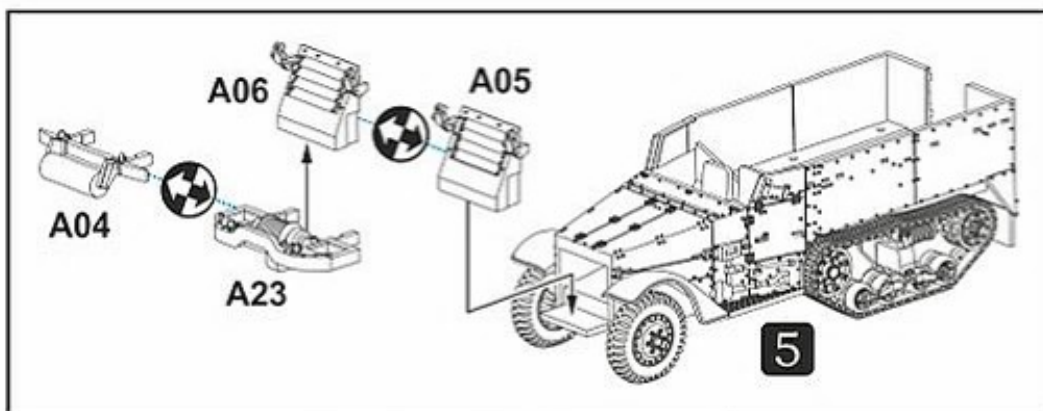
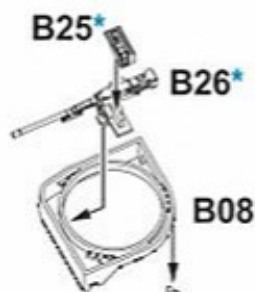

* Optional



HISTORICAL FACTS: The Carrier, Personnel Half Track M3, also known as the M3 Half Track, was an American armoured personnel carrier widely used by the Allies during World War Two and into the Cold War. Derived from the M2 Half Track Car, the slightly longer M3 was extensively produced, with over 41,000 units were manufactured. The M3 and its variants were supplied to the US Army and Marines, as well as British Commonwealth and Soviet Red Army forces, serving on all major fronts throughout the war. The M3A1 had the improved M49 machine gun ring mount over the right hand front seat. Between 1942 and 1943 all M3 Half-Tracks (standard and A1s) were continually upgraded. These improvements included a number of drive train, engine, and stowage improvements.

7 M3 / M3A1 unless marked

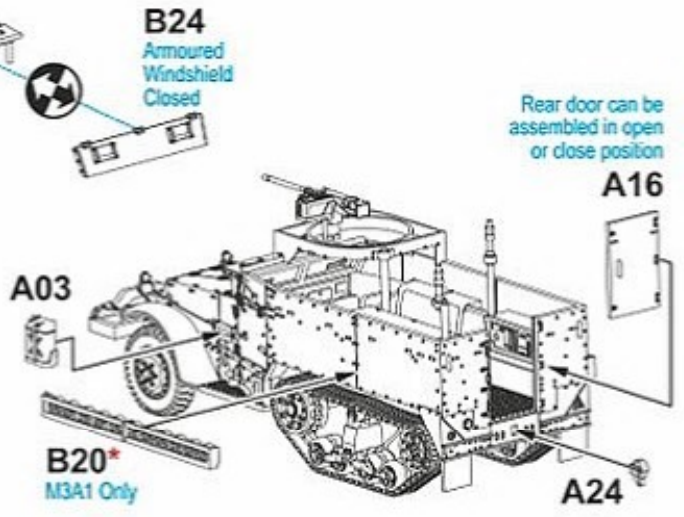
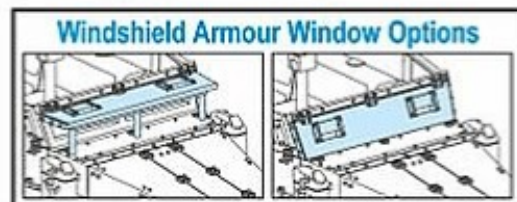
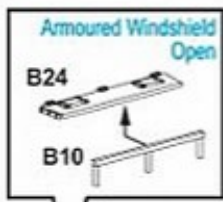
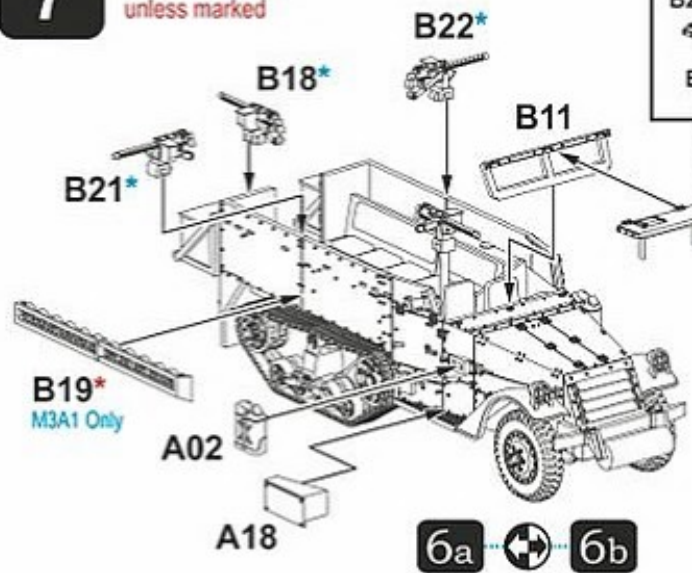

Rear door can be assembled in open or close position

6a 6b

* Optional