

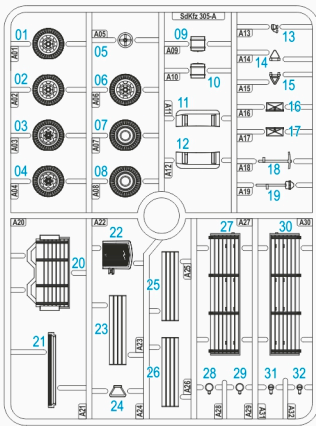

Product Code: **280026**

160325-1



A

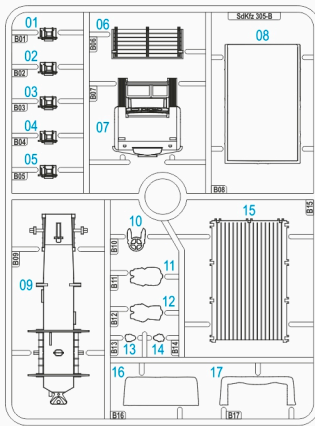

B

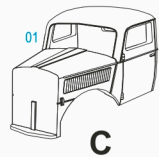

C



CAUTION

- When you use glue or paint, do not use near a naked flame, and use in a well-ventilated area.
- When assembling this kit, tools including knives are used. Extra care should be taken to avoid personal injury.
- Keep out of reach of small children.

Read carefully and fully understand the instructions before commencing assembly. Model supplied unpainted. Bases, scenery, glue and paint not included. Meaning of symbols used:



Choices



Optional



No glue



Drill hole



Bend



Cut or trim with care

 Please use **ABS Plastic Cement** for assembly.

WARNING

- THIS IS NOT A TOY
- INTENDED FOR COLLECTORS OF AGE 14 AND ABOVE
- CONTAINS SMALL PARTS AND POINTED COMPONENTS
- NOT SUITABLE FOR CHILDREN UNDER 6 YEARS OLD
- MODEL MAY VARY FROM IMAGE ON BOX
- READY TO ASSEMBLE PRECISION MODEL KIT

1

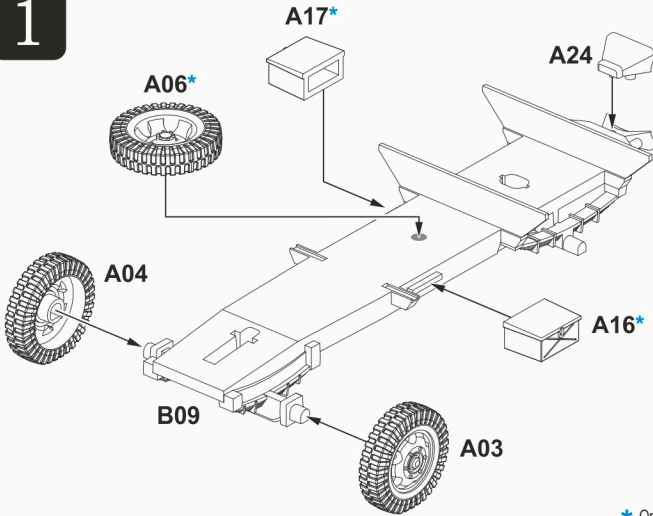

* Optional

WINDSHIELD TEMPLATE for experienced modellers

Use the template provided below if you decided to add a windshield to the truck. Attach the prepared windshield from the inside of the cab.

You can also download a digital copy of this template from our forum at forum.rubiconmodels.com under "Painting & Assembly Guides". To download any files, you must register as a forum member.

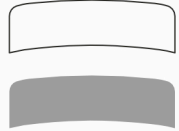

Size & Measurement:



HISTORICAL FACTS: The Opel Blitz series of 3-ton trucks (designated as **SdKfz 305**) proved the true backbone of German military strength in World War 2. Production began in April 1937 and proceeded into July 1944 to which some **70,000** 4x2 Opel Blitz trucks were delivered out of German factories. Even Daimler-Benz was ordered to produce the type in its original form, ending production of its own competing 3-ton class truck version. In 1944, a standardized German Army version was delivered, this without any Opel company markings on the truck and known as the **DB 701**. Seven main variants which include standard truck, heavy ambulance, radio or telephone communication van, fire truck, emergency vehicle, and fuel tanker. Some were even converted to mount AA guns for defence!

2

Assemble
FIRST!

1

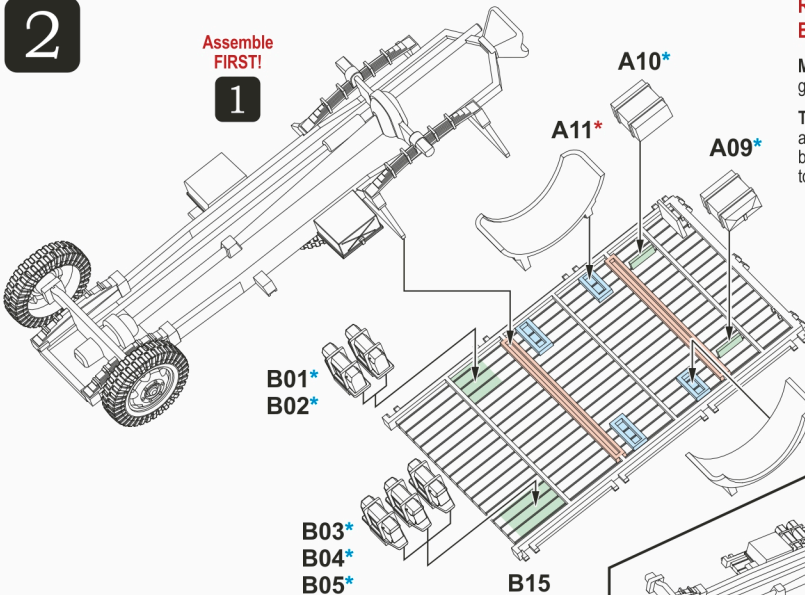

* Optional

READ THIS BEFORE ASSEMBLY*

MUST assemble **1** first before gluing other parts to **B15**.

Test fit to understand the assembly. Use the **colour guide** below if you are not sure what to do...

- Assemble **FIRST**
- Assemble **LAST**
- Optional Items

Visual Reference

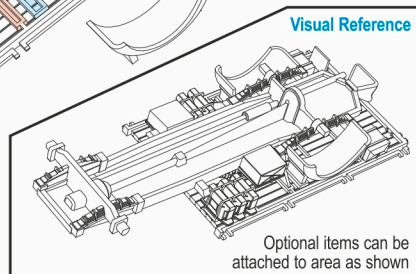

Optional items can be attached to area as shown

3

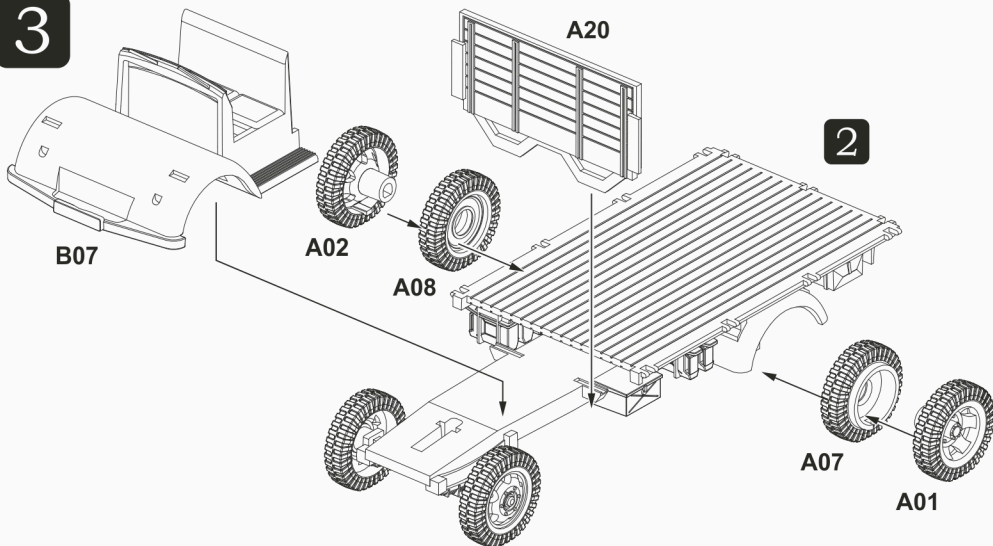

MODELLING TIPS:

Tailgate (B06) - The tailgate can be assembled in either closed or open position. When assembling the two side boards (A27 & A30), please make sure the lock is facing towards the rear as indicated in the diagram below.

Bench Seats (A23+A25+A26) - The benches are optional and can be assembled in parallel to the tailgate or placed by the side against the side boards.

Spare Tyre (A06) - Spare tyre is usually placed at the under-carriage of the truck (as shown in Step 1), but some had been placed on the head board inside the truck.



For our latest news, please visit our official Facebook page
<https://www.facebook.com/rubiconmodels>



Please also visit our Facebook Community page at
www.facebook.com/groups/RubiconModelsCommunity

Like our pages to show your support!

4

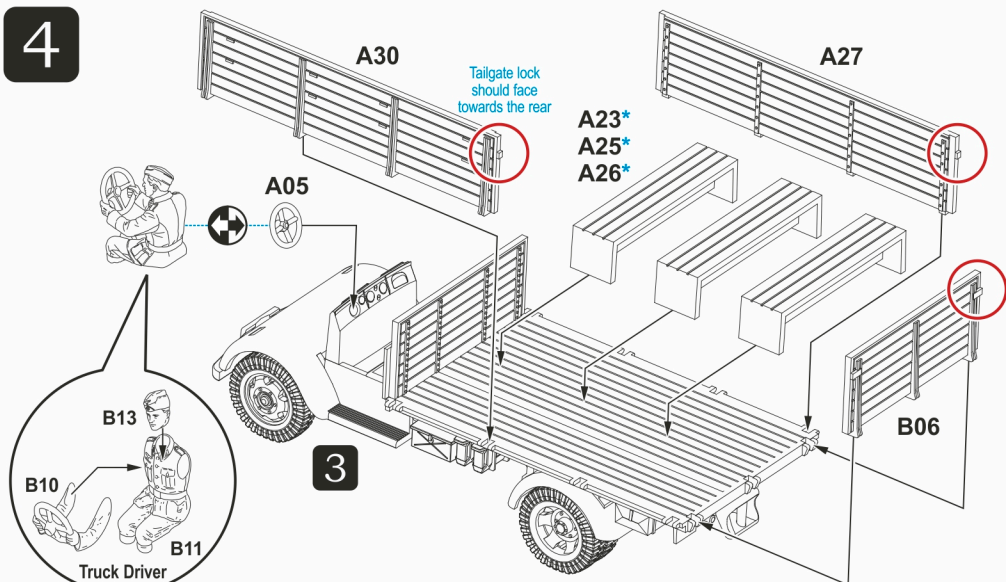

* Optional

5



Cargo Tow Indicator

The triangular tow indicator panel can be installed in upright (A15) or face-down (A14) position by punching two holes using the guides provided underneath the cab roof.

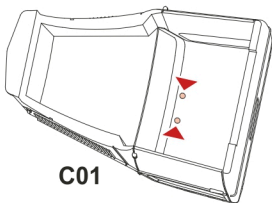

C01



Canvas Top Assembly

The rear tarpaulin of the detachable canvas top (B08) can be assembled in either closed (B16) or roll-up (B17) position. Choose accordingly...

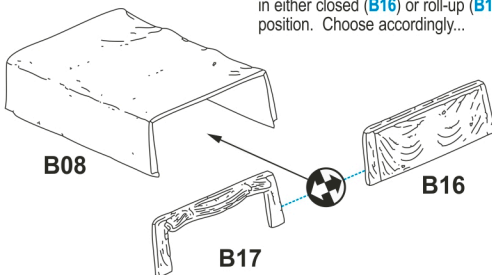

B08

B16

B17

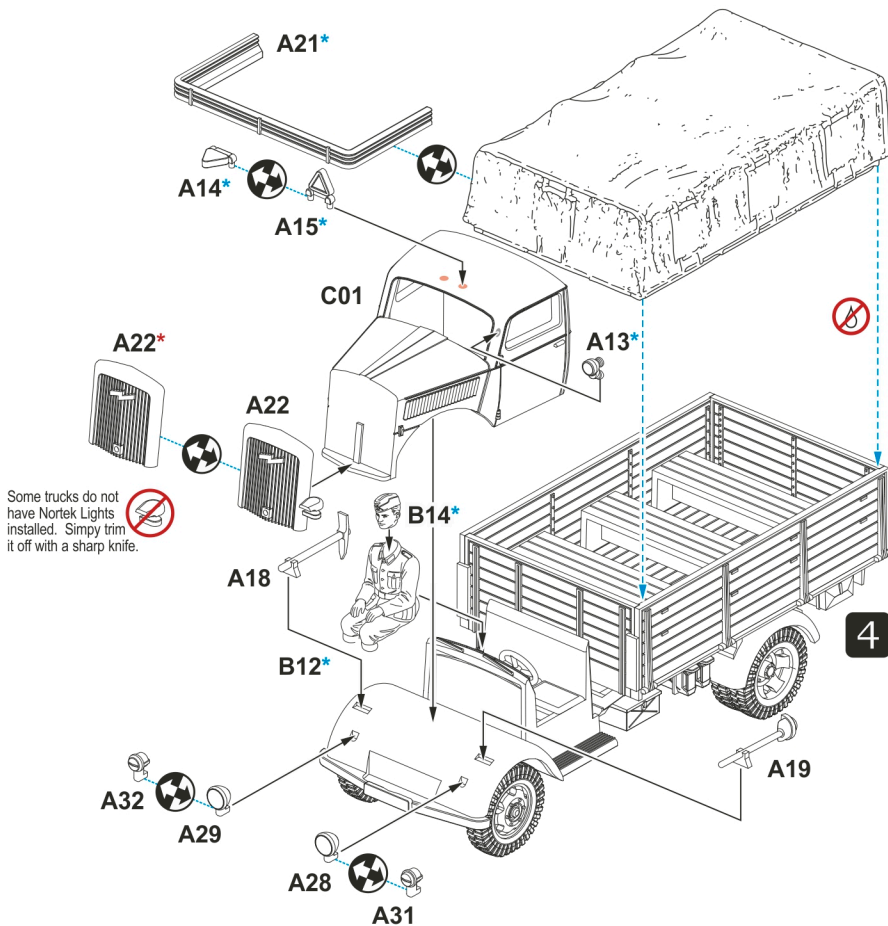

Some trucks do not have Nortek Lights installed. Simply trim it off with a sharp knife.

* Optional

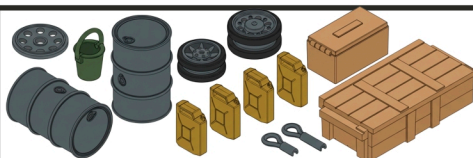

If you like this **SdKfz 305 3-ton 4x2 Cargo Truck** kit, you might also want to look at our 280022 **German Stowage Set 1** kit. An excellent companion product for your new truck!



Please also visit our Facebook page at <https://www.facebook.com/rubiconmodels>



and like our FB page to show your support!